



ALTRACK

AMD10W~30W Series
ISOLATED 10W~30W REGULATED SINGLE & DUAL OUTPUT DC/DC CONVERTERS

Features

- 1"x1"x0.4" Shielded Metal Case
- Efficiency to 90%
- 4:1 2:1 Input Range
- Regulated Outputs
- Input Under Voltage Protection
- Remote On/Off
- Continuous Over Load / Short Circuit Protection
- Meets UL/EN/IEC60950-1.CE Mark

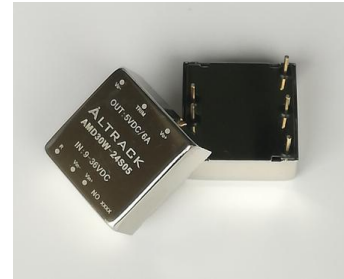

1500VDC ISOLATION

REMOTE CONTROL

UVP

OCP

SCP

SYNC

All Specifications Typical at Nominal Line, Full Load, and 25°C Unless Otherwise Noted.

Selection Guide

Order Code	Input Voltage (VDC)	Output Voltage (VDC)	Output Current (A)	Eff. (%)	Order Code	Input Voltage (VDC)	Output Voltage (VDC)	Output Current (A)	Eff. (%)
AMD10W-24S33	9~36	3.3	3	78	AMD20W-24S05	9~36	5	4	83
AMD10W-24S05	9~36	5	2	83	AMD20W-24S12	9~36	12	1.67	88
AMD10W-24S12	9~36	12	0.84	85	AMD20W-24S15	9~36	15	1.34	88
AMD10W-24S15	9~36	15	0.67	87	AMD20W-24D12	9~36	±12	0.84	87
AMD10W-24S24	9~36	24	0.42	87	AMD20W-24D15	9~36	±15	0.67	85
AMD10W-24D05	9~36	±5	1	85	AMD20W-48S05	18~75	5	4	83
AMD10W-24D12	9~36	±12	0.42	88	AMD20W-48S12	18~75	12	1.67	88
AMD10W-24D15	9~36	±15	0.34	88	AMD20W-48S15	18~75	15	1.34	87
AMD10W-48S33	18~75	3.3	3	78	AMD20W-48D12	18~75	±12	0.84	87
AMD10W-48S05	18~75	5	2	83	AMD20W-48D15	18~75	±15	0.67	85
AMD10W-48S12	18~75	12	0.84	85	AMD30W-24S05	9~36	5	6	88
AMD10W-48S15	18~75	15	0.67	87	AMD30W-24S12	9~36	12	2.5	89
AMD10W-48S24	18~75	24	0.42	87	AMD30W-24S15	9~36	15	2	90
AMD10W-48D05	18~75	±5	1	83	AMD30W-24S24	9~36	24	1.25	88
AMD10W-48D12	18~75	±12	0.42	88	AMD30W-24D15	9~36	±15	1	88
AMD10W-48D15	18~75	±15	0.34	88	AMD30W-48S05	18~75	5	6	88
AMD15W-24S33	9~36	3.3	4	78	AMD30W-48S12	18~75	12	2.5	89
AMD15W-24S05	9~36	5	3	83	AMD30W-48S15	18~75	15	2	89
AMD15W-24S12	9~36	12	1.25	85	AMD30W-48D12	18~75	±12	1.25	88
AMD15W-24S15	9~36	15	1	87	AMD30W-48D15	18~75	±15	1	88
AMD15W-24S24	9~36	24	0.63	87	AMD15W-110S33	43~160	3.3	4	78
AMD15W-24D05	9~36	±5	1.5	83	AMD15W-110S05	43~160	5	3	83
AMD15W-24D12	9~36	±12	0.63	88	AMD15W-110S12	43~160	12	1.25	85
AMD15W-24D15	9~36	±15	0.5	88	AMD15W-110S15	43~160	15	1	83
AMD15W-48S33	18~75	3.3	4	78	AMD15W-110S24	43~160	24	0.63	83
AMD15W-48S05	18~75	5	3	83	AMD15W-110D05	43~160	±5	1.5	80
AMD15W-48S12	18~75	12	1.25	85	AMD15W-110D12	43~160	±12	0.63	83
AMD15W-48S15	18~75	15	1	87	AMD15W-110D15	43~160	±15	0.5	80
AMD15W-48S24	18~75	24	0.63	87	AMD15-24S48	18~36	48	0.32	86
AMD15W-48D05	18~75	±5	1.5	83					
AMD15W-48D12	18~75	±12	0.63	88					
AMD15W-48D15	18~75	±15	0.5	88					

NO 'W' is 2:1 Input Voltage range



Specifications

INPUT CHARACTERISTICS

Input Voltage range	24Vin	W:9-36V
	48Vin	W:18-75V
	110Vin	W:43-160V
Under voltage lock out	Turn on @9Vinmin	8.8V
	Turn off @9Vinmin	8.0V
	Turn on @18Vinmin	17V
	Turn off @18Vinmin	16V
	Turn on @43Vinmin	42V
	Turn off @43Vinmin	41V
Input Surge Voltage(100ms)	36Vinmax	50V max
	75Vinmax	80V max
	160Vinmax	180V max
Input Filter		LC Type
Positive Logic Remote on/off		See Note

OUTPUT CHARACTERISTICS

Voltage Accuracy		±1% max
Transient Response	25% Step Load Change	
	Error band	±5% Vout
	Recovery Time	<500us
External Trim Adj.Range		90-110%Vout
Temperature Coefficient		±0.03%/°C
Short Circuit Protection		Continuous
Line Regulation		±0.2%max
Load Regulation		±0.5%max
Ripple and Noise		100 mVp-p typ.
Output Current Limit		110%-160%
Start-up Time		50ms max.

GENERAL CHARACTERISTICS

Eff.		See Note
Isolation Voltage	I/O	1500 VDC
	I/CASE	1500 VDC
	O/CASE	500 VDC
Isolation Resistance	(500VDC)	10 ⁷ Ohms min
Isolation Capacitance		1000pF typ.
Switching frequency		500kHz typ.
Case Temperature		105°C max.
Cooling		Natural Convection
Storage Temperature		-55°C to +105°C
Humidity		95%RH max
MTBF	MIL-HDBK-217F	1000K.Hrs
Dimensions		1.0 x 1.0 x 0.40 inch 25.4 x 25.4 x 10.2 mm
Case Material		Six-Sided shield metal case
Weight		20g

EMC CHARACTERISTICS

EMI	Conduction	EN 55032, FCC part 15	B
	Radiation	EN 55032, FCC part 15	B
EMS		EN55024	
	ESD	EN 61000-4-2 Air ± 6kV, Contact±4kV	B
	Radiated immunity	EN 61000-4-3 10V/m	A
	Fast transient	EN 61000-4-4 ±2kV	B
	Surge	EN 61000-4-5 ±2kV	B
	Conducted immunity	EN 61000-4-6 10Vrms	A

MECHANICAL DIMENSIONS & PIN CONNECTION

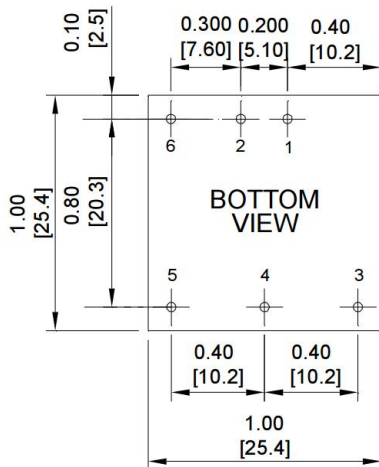

PIN CONNECTION

Pin	Single	Dual
1	+Input	+Input
2	-Input	-Input
3	+V Output	+V Output
4	Trim	Common
5	-V Output	-V Output
6	Remote	Remote

Derating Curve

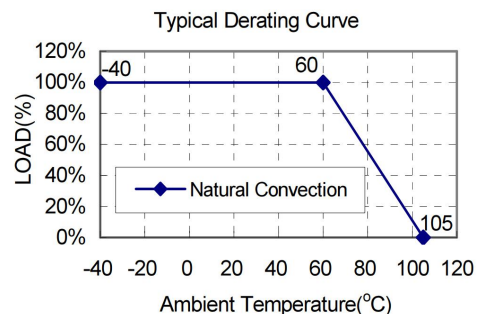



Design reference

Application Circuit

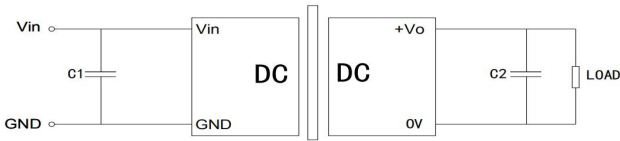

C1 Typical Value: recommend 2.2uF/1W output power
 C2 Typical Value: recommend 100uF/1A output current

Derating Curve VS Input Voltage (When Power is 30W)

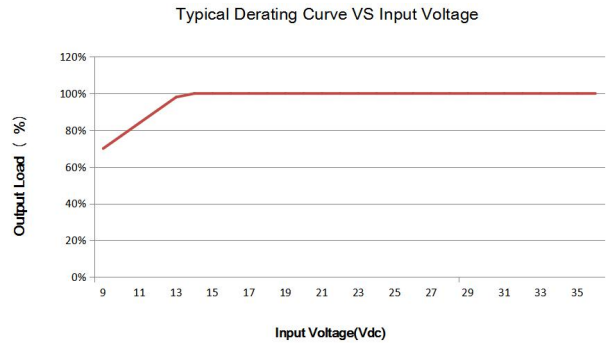

Remote on/off control

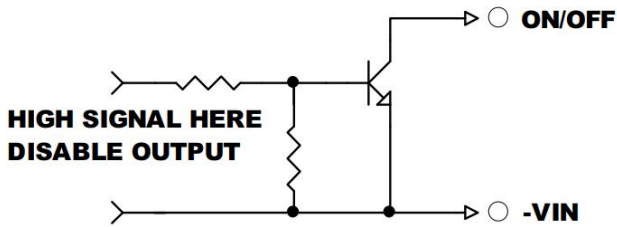

External Output Trim

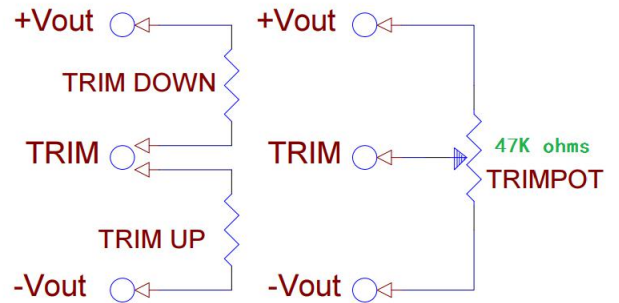

EMC Recommend Circuit

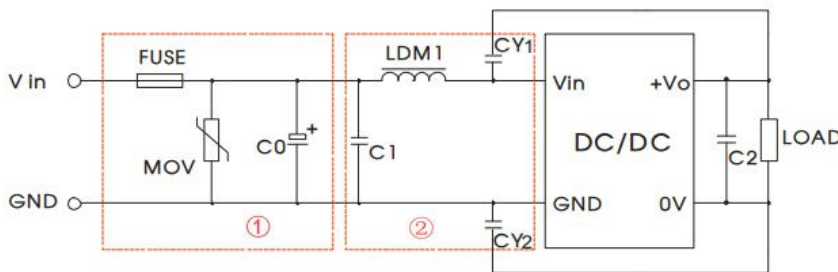

Position	Parameter
FUSE	According to the actual choice
MOV	According to the actual choice
C0	220uF Electrolytic capacitor
C1	2.2uF/1W output power
C2	100uF/1A output current
LDM1	According to the actual choice
CY1	1nF/2KV
CY2	1nF/2KV

The first part is used for EMC testing, and the second part is used for EMI filtering, which can be selected according to requirements.

Note

1. Measured From High Line to Low Line.
2. Measured From Full Load to min. Load.
3. The output ripple and noise is measured with 10uF Aluminium electrolytic capacitor and 0.1uF Ceramic capacitor across output.
4. Positive Logic
 Module ON >+3.5V or Open Circuit
 Module OFF < 0.5Vdc or Short to -input
5. Operation Ambient Temperature Range
 - 40°C ~85°C
 Derating, Above 60°C, Linearly to Zero Power at +105°C